



Understanding the KDF File (and how it relates to Programs, Combis, and PCG)

Revision 14-Dec-2008 © by Stephen Kay

What is stored in a KDF file?

The diagram to the right is a representation of the contents of a KDF File. There are a number of Performance Banks (which correspond to banks of Combis and Programs in the M3, according to the setting of the Bank Type parameter in the Performance Bank Display Window), a number of GE Banks, a number of Template Banks, and several banks of other data for various purposes.

As shown, Performances are actually comprised of two separate pieces that are associated with each other: the Performance Bank piece (that stores the KARMA-related parameters in the Performance that you are editing in the KM3 software), and the PCG Bank piece (that stores the PCG data for that Program or Combi, as the keyboard stores it, which contains all of the synthesizer parameters as well.) You do not actually see the PCG Bank pieces in the KDF window, but they are inside the file. (You don't see the Name pieces or Note Map Data in the KDF Window either, but they are accessed in various name selection dialogs and the Note Map Editor.)

The PCG piece for each Performance is basically what you get when you do a SysEx dump of a Program or Combi. It contains the KARMA settings as they are stored in the M3, plus all of the other synthesizer and effects related parameters – the entire Program or Combi.

The Performance piece contains a different non-Korg representation of the KARMA parameters, as they are stored in the KARMA software. When you are using the software, the internal KARMA of the keyboard is disabled, and you are hearing the effect of the Performance and GE settings that you are editing in the software. In other words, in normal use, the software replaces the keyboard's internal KARMA while you are using it.

It's important to note that when you select a Performance in KARMA software, it does not dump any Sysex data to the keyboard. It simply sends a Program Change and Bank Change that selects the corresponding Program or Combi. So when working with the keyboard and the software, you should be editing the KARMA settings in the software, but editing other sound-related parameters in the key-

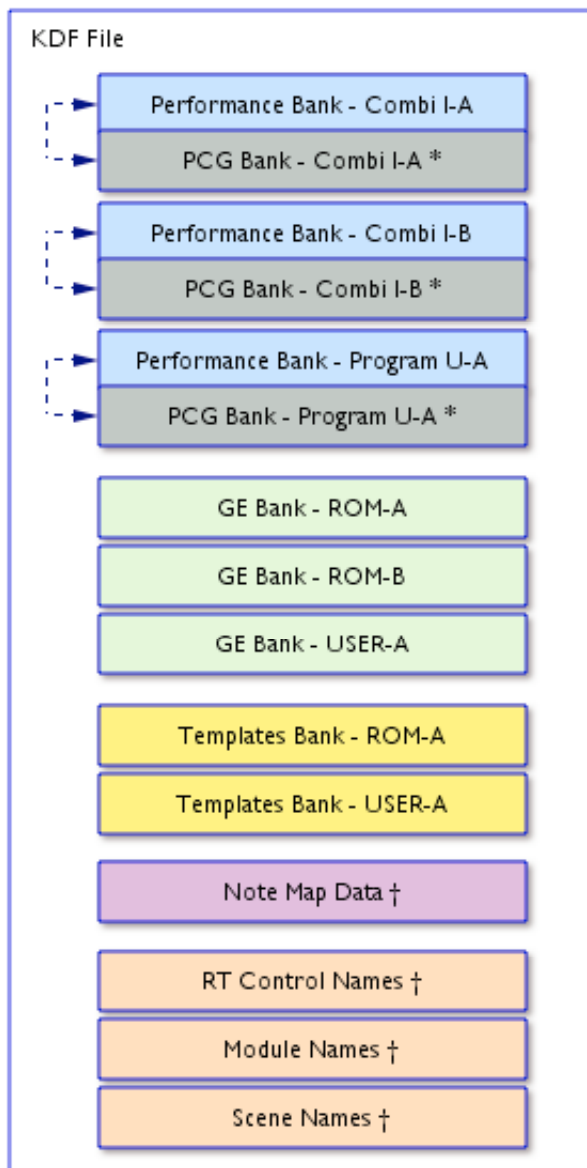

* Hidden Internally

† Not visible in the KDF Window,
but visible elsewhere in the application

board itself, and storing the changes in the location that matches the Performance in the KDF file. (Yes, you can actually choose a different location to be called up when a Performance is selected, in the Performance Editor > Korg page, but that is not recommended except for advanced users and special situations.)

When you edit a non-KARMA parameter in the M3 itself, such as the volume or pitch transpose of a timbre in a Combi, or the Program in a timbre, or the IFX/MFX, you should save those changes in the M3 in the normal fashion. However, this does not reflect that change to the PCG Bank piece of the Performance that is currently stored/loaded in the software. If you were to send that Performance back to the keyboard via Sysex, it would revert to the previous settings (since you would be sending the "old" PCG data.)

How does this relate to the sending and receiving of Performances?

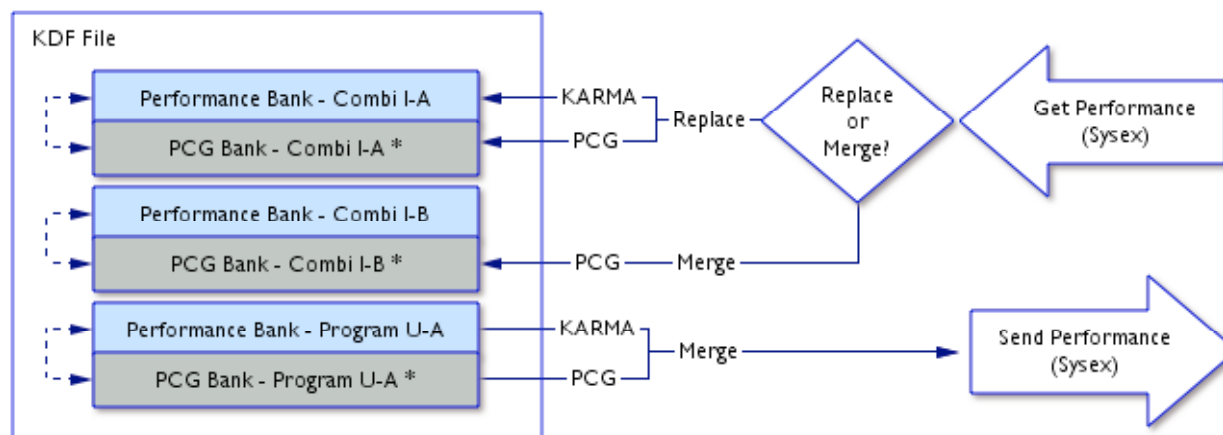

The diagram below explains the relationship between sending and receiving Sysex of Programs and Combis between KM3 and the M3, and the stored data in the KDF file.

When you "Get Performance" from the M3, you have a choice of "Replace" or "Merge":

Replace: The PCG data of the Program/Combi is stored in the PCG Bank piece in the correct location, replacing what was previously there. This includes the KARMA settings as presently stored in the keyboard. Then, those KARMA settings are converted to the KM3 format, and stored in the Performance Bank piece, replacing the previous KARMA settings. Therefore, the KARMA in the KDF and the KARMA in the M3 are now a duplicate of each other.

Merge: The PCG data of the Program/Combi including the current KARMA Settings replaces the data in the PCG Bank piece, same as above. However, nothing is done to the stored KM3 KARMA settings; they stay as they are, with all your edits. This is part one of how you combine edits in the keyboard with edits in KM3.

When you "Send Performance" to the M3, the KARMA settings of KM3 are first converted to Korg's format, then combined with the PCG data in a temporary buffer, replacing the KARMA settings in the PCG piece, and the new PCG Program/Combi is sent to the M3. This is the second part of how you combine edits in the software with edits in the keyboard, and get the whole thing back into the M3.

Summary of Editing Procedure

- Edit the KARMA related parameters in KARMA M3.
- Edit all other settings in the M3.
- When finished, "Get Performance" from the M3 via Sysex, and Merge it into the location of the KDF File, preserving the KARMA edits you have done in the software.
- Then "Send Performance" back to the M3 via Sysex, into the same location, thereby combining the software's KARMA edits and the PCG data and replacing what was previously in the M3.

This is explained in more detail, along with an in-depth real-world example, in the Tutorial "Editing a Combination with KARMA M3, and Merging the data with the M3":

[\(Editing And Merging A Combi.pdf\)](#).

Additional Information

Note that it is not necessary or required to have the PCG Bank pieces stored in the KDF File. On one hand, it does make the file about 40% larger, although that's not a large concern in this day and age. On the other hand, you cannot send the data back and forth via Sysex without the PCG component – KM3 will ask you to add it if you try to send data from a KDF file that does not contain it. If you are never planning to use the material you create in KM3 software without running KM3, then there's really no need to be sending and receiving Performances back and forth.

In any case, at the top of the KDF window you will see the "Contains PCG Data" checkbox. If you turn this off, it strips the PCG Bank pieces out of the file. Saving it in that state would result in a smaller file. If you turn it back on, it would then add blank initialized PCG Data to the file – useful, perhaps, if you want to initialize a bank in the M3 and there's no other way to do it. A new KDF File (File Menu > New) also contains initialized PCG Data, as do banks added with the Bank Add item from the KDF Window Menu Button (when the "Contains PCG Data" checkbox is on, of course.)