



Understanding the KDF File (and how it relates to Programs, Combis, and PCG)

Revision 18-Dec-2008 © by Stephen Kay

Why do you need to know this?

Due to the fact that the M50 has no internal KARMA function, you don't really need to worry about this if you never plan to send and receive backups of your data into the KDF file. If you just backup your M50 sounds to the SD card, and keep the KARMA settings in the KDF file, it really doesn't matter whether the KDF stores PCG data or not.

However, if you wish to send and receive the M50's internal data and store it as part of the KDF file, then you need to read this and understand how it works.

What is stored in a KDF file?

The diagram to the right is a representation of the contents of a KDF File. There are a number of Performance Banks (which correspond to banks of Combis and Programs in the M50, according to the setting of the Bank Type parameter in the Performance Bank Display Window), a number of GE Banks, a number of Template Banks, and several banks of other data for various purposes.

As shown, Performances are actually comprised of two separate pieces that are associated with each other: the Performance Bank piece (that stores the KARMA-related parameters in the Performance that you are editing in the KM50 software), and the PCG Bank piece (that stores the PCG data for that Program or Combi, as the keyboard stores it, which contains all of the synthesizer parameters as well.) You do not actually see the PCG Bank pieces in the KDF window, but they are inside the file. (You don't see the Name pieces or Note Map Data in the KDF Window either, but they are accessed in various name selection dialogs and the Note Map Editor.)

The PCG piece for each Performance is basically what you get when you do a SysEx dump of a Program or Combi. It contains all of the M50's synthesizer and effects related parameters – the entire Program or Combi.

The Performance piece contains the KARMA parameters, as they are stored in the KARMA software. When you are using the software, the software generates the KARMA Performance using the settings in the Performance piece, while calling up the corresponding location on the M50 that it matches.

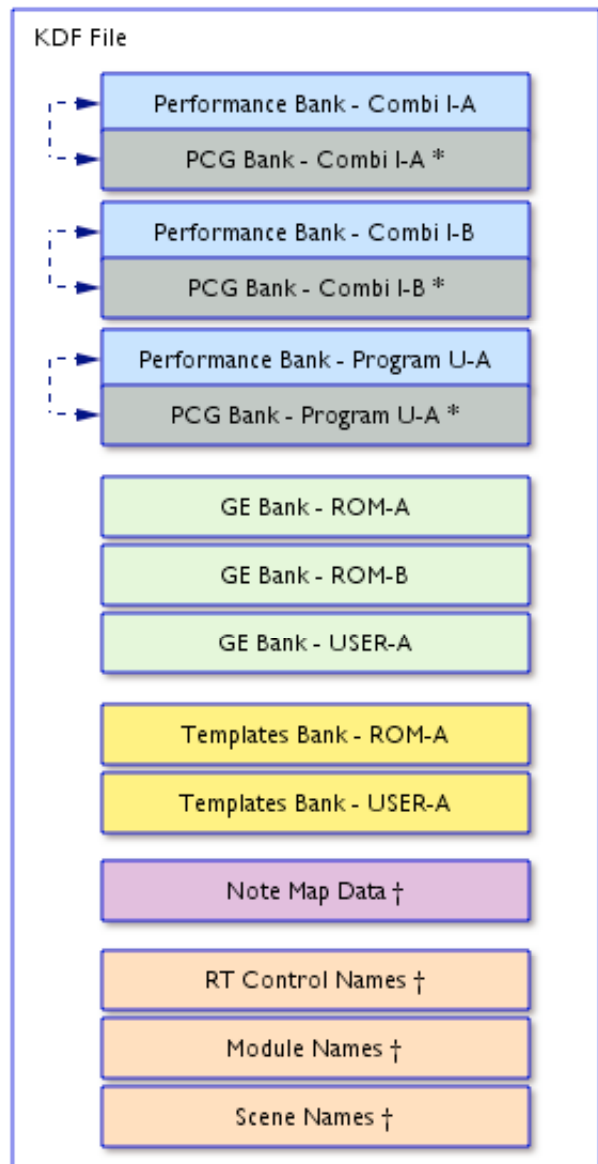

* Hidden Internally

† Not visible in the KDF Window,
but visible elsewhere in the application

It's important to note that when you select a Performance in KARMA software, it does not dump any Sysex data to the keyboard. It simply sends a Program Change and Bank Change that selects the corresponding Program or Combi. So when working with the keyboard and the software, you should be editing the KARMA settings in the software, and editing other sound-related parameters in the keyboard itself, and storing the changes in the location that matches the Performance in the KDF file. (Yes, you can actually choose a different location to be called up when a Performance is selected, in the Performance Editor > Korg page, but that is not recommended except for advanced users and special situations.)

When you edit a non-KARMA parameter in the M50 itself, such as the volume or pitch transpose of a timbre in a Combi, or the Program in a timbre, or the IFX/MFX, you should save those changes in the M50 in the normal fashion. However, this does not reflect that change to the PCG Bank piece of the Performance that is currently stored/loaded in the software. If you were to send that Performance back to the keyboard via Sysex, it would revert to the previous settings (since you would be sending the "old" PCG data.)

How does this relate to the sending and receiving of Performances?

The diagram below explains the relationship between sending and receiving Sysex of Programs and Combis between KM50 and the M50, and the stored data in the KDF file. (XXX- need updated)

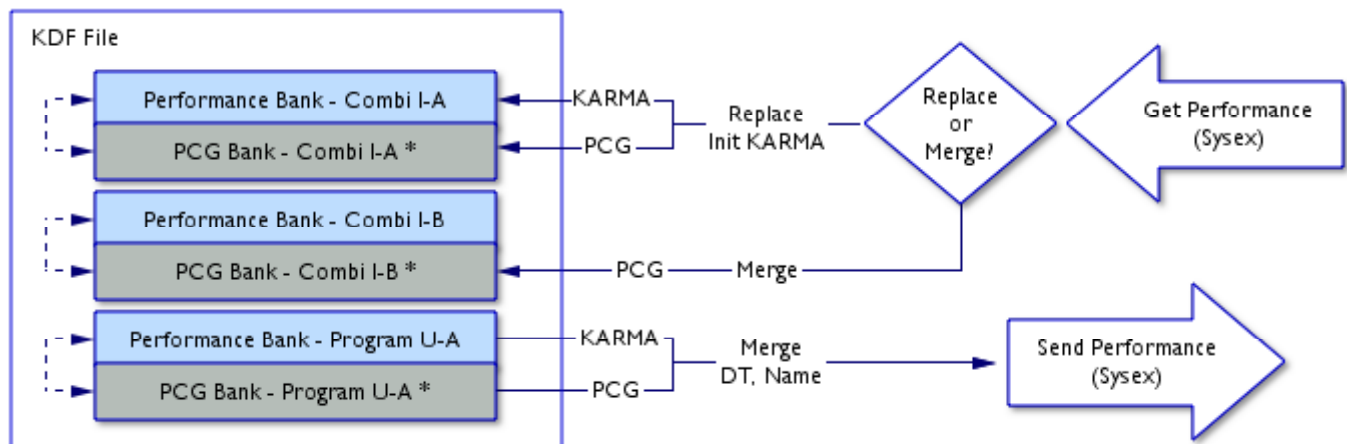

When you "Get Performance" from the M50, you have a choice of "Replace" or "Merge":

Replace: The PCG data of the Program/Combi is stored in the PCG Bank piece in the correct location, replacing what was previously there. Since the M50 does not have any internal KARMA settings, initialized KARMA data is created in the Performance piece, replacing whatever KARMA data was there before. Furthermore, the Drum Track On/Off and Switch Mode settings, which are not technically part of KARMA, but are included in the software to allow you to conveniently edit and control the Drum Track along with the KARMA settings are replaced in those initialized Performances such that they reflect the state of the M50. Additionally, the name and category of each Performance in the KARMA data is replaced with the name and category as it exists in the M50. This results in the KDF file containing the PCG exactly as it is in the keyboard, plus completely initialized KARMA settings (except for those two Drum Track settings.) You do not normally use this option unless you were importing other data that has no KARMA settings and you wish to "KARMA-fy" it.

Merge: The PCG data of the Program/Combi replaces the data in the PCG Bank piece, same as above. However, nothing is done to the stored KM50 KARMA settings and Drum Track settings; they stay as they are, with all your edits. This includes the name and category of the Performance. This is part one of how you combine edits in the keyboard with edits in KM50. This is the option you will normally use, which is why the dialog defaults to it.

When you "Send Performance" to the M50, the two Drum Track settings of KM50, the Category, and the Name are first combined with the PCG data in a temporary buffer, replacing those settings in the PCG piece, and the new PCG Program/Combi is sent to the M50. This is the second part of how you combine edits in the software with edits in the keyboard, and get the whole thing back into the M50.

Note: when you "Get Performance Bank", you have a third option, which is "Create New Bank" – this does essentially the same thing as the "Replace" option above, while creating a completely new bank in the KDF file, leaving the original bank as it is.

Summary of Editing Procedure

- Edit the KARMA related parameters in KARMA M50.
- Edit the Drum Track On/Off and Switch Mode in KARMA M50's Realtime Controls Editor (if you are using them in the Performances).
- Edit all other settings in the M50.
- When finished, "Get Performance" from the M50 via Sysex, and Merge it into the location of the KDF File, preserving the KARMA edits and Drum Track settings you have done in the software.
- Then "Send Performance" back to the M50 via Sysex, into the same location, thereby combining the software's Drum Track edits and the PCG data and replacing what was previously in the M50.

This is explained in more detail, along with an in-depth real-world example, in the Tutorial "Editing a Combination with KARMA M50, and Merging the data with the M50":

[\(Editing And Merging A Combi.pdf\)](#).

Additional Information

Note that it is not necessary or required to have the PCG Bank pieces stored in the KDF File. On one hand, it does make the file about 40% larger, although that's not a large concern in this day and age. On the other hand, you cannot send the data back and forth via Sysex without the PCG component – KM50 will ask you to add it if you try to send data from a KDF file that does not contain it. If you are never planning to use KM50 as a means of backing up the PCG data that goes with the KARMA Performances in a particular KDF file, then there's really no need to be sending and receiving Performances back and forth.

In any case, at the top of the KDF window you will see the "Contains PCG Data" checkbox. If you turn this off, it strips the PCG Bank pieces out of the file. Saving it in that state would result in a smaller file. If you turn it back on, it would then add blank initialized PCG Data to the file – useful, perhaps, if you want to initialize a bank in the M50 and there's no other way to do it. A new KDF File (File Menu > New) also contains initialized PCG Data, as do banks added with the Bank Add item from the KDF Window Menu Button (when the "Contains PCG Data" checkbox is on, of course.)